

## TMA09A Series

### FEATURES

- Small size and Lightweight
- Dip-solderable, high reliable and long life
- Low voltage and low drain

### APPLICATIONS

- Pager, Mobile phone, cordless telephone
- Computer and peripheral units
- Various home appliances



Noryl Housing material, Black  
Connect Leads: Pins

### DIMENSIONS ( unit in mm)

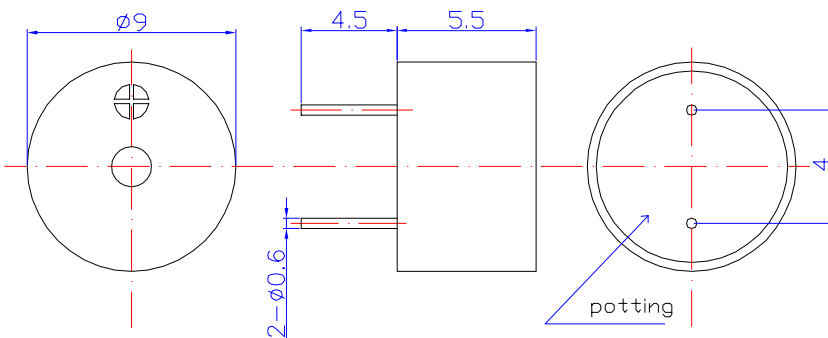

### CHARACTERISTICS

(Frequency vs SPL)

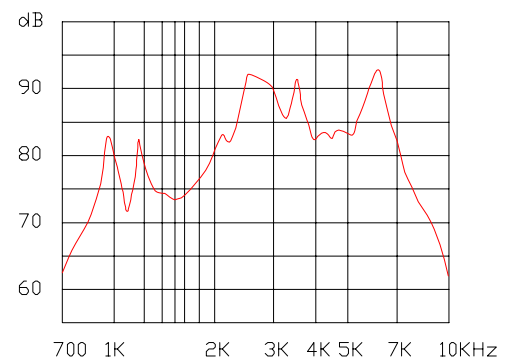

### SPECIFICATIONS (all data taken at 25 °C unless otherwise specified)

Part Number	Unit	TMA09A2701P	TMA09A2703P	TMA09A2705P
Rated Voltage	V	1.5	3	5
Operating Voltage	V	1 ~ 3	2 ~ 4	4 ~ 6
* Max. Rated Current	mA	80	60	60
Coil Resistance	Ohm	5.5 ± 1	25 ± 3	40 ± 4
* Min. SPL at 10 cm	dB	80	85	85
Resonant Frequency	Hz	2731		
Operating Temperature	°C	-20 ~ +70		
Storage Temperature	°C	-30 ~ +80		
Weight	g	1		

\* Value applying rated voltage (resonant frequency, 1/2 duty, square wave)